

Novel *GABRG2* mutations cause familial febrile seizures

OPEN

Morgane Boillot
Mélanie Morin-Brureau,
PhD
Fabienne Picard, MD,
PhD
Sarah Weckhuysen, MD,
PhD
Virginie Lambrecq, MD,
PhD
Carlo Minetti, MD, PhD
Pasquale Striano, MD,
PhD
Federico Zara, PhD
Michele Iacomino, PhD
Saeko Ishida, PhD
Isabelle An-Gourfinkel,
MD, PhD
Mailys Daniau
Katia Hardies, PhD
Michel Baulac, MD
Olivier Dulac, MD
Eric Leguern, MD, PhD
Rima Nabbout, MD,
PhD
Stéphanie Baulac, PhD

Correspondence to
Dr. Baulac:
stephanie.baulac@upmc.fr

ABSTRACT

Objective: To identify the genetic cause in a large family with febrile seizures (FS) and temporal lobe epilepsy (TLE) and subsequently search for additional mutations in a cohort of 107 families with FS, with or without epilepsy.

Methods: The cohort consisted of 1 large family with FS and TLE, 64 smaller French families recruited through a national French campaign, and 43 Italian families. Molecular analyses consisted of whole-exome sequencing and mutational screening.

Results: Exome sequencing revealed a p.Glu402fs*3 mutation in the $\gamma 2$ subunit of the GABA_A receptor gene (*GABRG2*) in the large family with FS and TLE. Three additional nonsense and frameshift *GABRG2* mutations (p.Arg136*, p.Val462fs*33, and p.Pro59fs*12), 1 missense mutation (p.Met199Val), and 1 exonic deletion were subsequently identified in 5 families of the follow-up cohort.

Conclusions: We report *GABRG2* mutations in 5.6% (6/108) of families with FS, with or without associated epilepsy. This study provides evidence that *GABRG2* mutations are linked to the FS phenotype, rather than epilepsy, and that loss-of-function of GABA_A receptor $\gamma 2$ subunit is the probable underlying pathogenic mechanism. *Neurol Genet* 2015;1:e35; doi: 10.1212/NXG.0000000000000035

GLOSSARY

FS = febrile seizures; **GEFS+** = genetic epilepsy with febrile seizures plus; **GTCS** = generalized tonic-clonic seizures; **NMD** = nonsense-mediated-decay system; **TCS** = tonic-clonic seizures; **TLE** = temporal lobe epilepsy.

Febrile seizures (FS) are the most frequent convulsive event in early infancy, affecting an estimated 2%–5% of children.¹ They usually occur between 6 months and 5 years of age in the presence of fever. The prognosis is usually good, although children who have experienced FS have a higher risk of developing epilepsy later in life. Despite a clear genetic component, the genetics of FS is still poorly understood.^{2,3} Sodium channel and GABA_A receptor gene mutations have been reported in familial syndromes including FS, such as genetic epilepsy with febrile seizures plus (GEFS+).⁴ Mutations in 3 ion channel genes collectively account for ~15% of GEFS+ families: *SCN1B* encoding the voltage-gated sodium channel $\beta 1$ subunit,⁵ *SCN1A* encoding the $\alpha 1$ subunit of the voltage-gated type I sodium channel,⁶ and *GABRG2* encoding the $\gamma 2$ subunit of the GABA_A receptor gene.⁷ Mutations in the *SCN1A* gene are the most frequent cause of GEFS+ to date.^{8–10} Recently, mutations in *STX1B*, encoding the presynaptic protein syntaxin-1B, were found in 6 families with FS and epilepsy.¹¹ We performed whole-exome sequencing in a large French family with FS and

From Sorbonne Universités (M.B., S.I., M.D., S.B., M.M.-B., E.L., S.W., M.B., V.L., I.A.-G.), UPMC Univ Paris 06, UM 75, ICM; INSERM, U1127 (M.B., S.I., M.D., S.B., M.M.-B., E.L., S.W., M.B., V.L., I.A.-G.), ICM; CNRS (M.B., S.I., M.D., S.B., M.M.-B., E.L., S.W., M.B., V.L., I.A.-G.), UMR 7225, ICM; ICM (M.B., S.I., M.D., S.B., M.M.-B., E.L., S.W., M.B., V.L., I.A.-G.), Paris, France; Department of Neurology (F.P.), University Hospitals of Geneva (HUG), Switzerland; Centre de Référence Épilepsies Rares, Epilepsy Unit (S.W., M.B., V.L., I.A.-G.), and Département de Génétique et de Cytogénétique (E.L.), AP-HP Groupe Hospitalier Pitié-Salpêtrière, Paris, France; Pediatric Neurology and Muscular Diseases Unit, Department of Neurosciences, Rehabilitation, Ophthalmology, Genetics, Maternal and Child Health, University of Genova (C.M., P.S.), and Laboratory of Neurogenetics, Department of Neurosciences (F.Z., M.I.), “G. Gaslini” Institute, Genova, Italy; Neurogenetics Group, VIB-Department of Molecular Genetics (K.H.), and Laboratory of Neurogenetics, Institute Born-Bunge (K.H.), University of Antwerp, Belgium; Centre de Référence Épilepsies Rares (O.D., R.N.), Department of Pediatric Neurology, Necker Enfants Malades Hospital, AP-HP, Paris; INSERM (O.D., R.N.), U1129, Necker, Paris, France; and University Paris Descartes (O.D., R.N.), Paris, France.

Funding information and disclosures are provided at the end of the article. Go to Neurology.org/ng for full disclosure forms. The Article Processing Charge was paid by the Institut du Cerveau et de la Moelle (ICM).

This is an open access article distributed under the terms of the Creative Commons Attribution-NonCommercial-NoDerivatives License 4.0 (CC BY-NC-ND), which permits downloading and sharing the work provided it is properly cited. The work cannot be changed in any way or used commercially.

temporal lobe epilepsy (TLE) and identified a pathogenic frameshift mutation in the *GABRG2* gene. We subsequently identified *GABRG2* mutations in 5 of 107 families with FS.

METHODS Patients. The French cohort consisted of 64 families with FS with or without epilepsy. All families were recruited through a national French campaign on genetic studies of familial FS conducted by Généthron in 1998–2000 (J.F. Prud'homme, Evry, France). Inclusion criterion for this cohort was the presence of at least 3 family members with FS (with or without associated epilepsy) with a transmission compatible with an autosomal dominant trait. Family members underwent clinical assessment using a detailed questionnaire. Information was also obtained retrospectively from medical records. Proband of all families were negative for *SCN1A* and *SCN1B* point mutations.

The Italian cohort consisted of 43 families with at least 2 first-degree relatives with FS, with or without epilepsy. Patient evaluation included details on clinical features of seizures (semiology, precipitating factors, duration), family and personal history of seizures/epilepsy, and developmental milestones. All the probands were negative for *SCN1A* mutations.

Standard protocol approvals, registrations, and patient consents. Written informed consent was obtained from all participants (or the parents of minors). The study was performed with the approval of the Cochin-Port-Royal Hospital Ethics Committee and the G. Gaslini Institute (No. 003771-35).

Whole-exome sequencing. Exome sequencing was performed on genomic DNA from peripheral blood of 3 affected members (A/II-1, A/II-4, and A/II-9) of family A. Targeted exome sequencing, library preparation, capture (Human All exon kit V4+UTRs, 70 Mb, Agilent, Interactive Biosoftware, Rouen, France), sequencing, and variant detection and annotation were performed by IntegraGen (Evry, France) using a previously described procedure.¹² Variants with low quality (<20) and low VQSLOD (logarithm of odds ratio that a variant is real vs not under the trained gaussian mixture model) (<0) were filtered out. Variants with a read depth >30 and allele read frequency >0.30 were filtered. High-quality variants were further filtered for those predicted to affect the protein-coding sequence (nonsense, missense, frameshift, or essential splice-site) and with a minor allele frequency (<1%) in the exome variant server (<http://evs.gs.washington.edu/EVS/>).

Mutational screening of *GABRG2*. Follow-up screening of *GABRG2* was done by Sanger sequencing in the 43 probands of the Italian cohort as previously described.¹³ Screening in the cohort of 64 probands from French families was performed using a targeted epilepsy gene panel (SeqCapEZ custom design, Roche NimbleGen) including *GABRG2*, *GABRA1*, *STX1B*, *PRRT2*, *CHRNA4*, *CHRNA2*, *CHRN2*, *LGII*, *DEPDC5*, *KCNT1*, and *EFHC1*. Quality of raw sequencing data was assessed with the FASTQC tool. Reads were trimmed with Trimmomatic. BWA was used to align reads on human genome (hg19). Finally, GATK best practices were applied to call variants. Variants with low quality (<20) were excluded. Variants with a read depth >30 and allele read frequency >0.30 were filtered. We selected heterozygous nonsynonymous variants with frequency <1% in the exome variant server, affecting the protein-coding sequence (nonsense, missense, frameshift, or essential splice-site) and predicted to be damaging by at least 1 of 2 in silico prediction tools (Sift, <http://sift.jcvi.org/>; PolyPhen-2, <http://genetics.bwh.harvard.edu/pph2/>). We followed the guidelines for assigning

causality of sequence variants in human disease as outlined.¹⁴ Coverage of *GABRG2* was satisfactory (>250×) except for exon 6, which was subsequently analyzed by traditional Sanger sequencing. Filtered variants were validated by Sanger sequencing, and segregation was analyzed in all available family members. Impact of mutations was assessed with Alamut version 2.4.3 (Interactive Biosoftware). *GABRG2* mutations were mapped on the immature peptide, according to the current convention.^{15,16} We compared the frequency of rare nonsynonymous *GABRG2* variants (including missense, nonsense, essential splice-site, in-frame Indels) identified in patients with epilepsy and those present in 33,370 European cases from the publicly available Exome Aggregation Consortium (ExAC) database (<http://exac.broadinstitute.org>) using Fisher exact tests (accessed July 2015).

Linkage analysis. Pairwise LOD scores were calculated using the MLINK program of the FASTLINK package version 4.1 assuming an autosomal dominant trait for FS with disease allele frequency of 0.01 and incomplete penetrance of 85%. Because the frequency of FS in the general population is approximately 2%–5%, we used a phenocopy rate of 3% as previously reported.¹⁷ We considered as affected all individuals with FS.

CGH array. CGH array was performed in the 43 probands of the Italian cohort using a custom 105K Agilent CGH array containing 44K backbone genome-wide probes and approximately 60K high-density probes spanning 440 genes encoding for ion channels (list available on request) according to previously described protocols and bioinformatics pipelines.¹⁸

RESULTS Exome sequencing. Exome sequencing revealed a pathogenic mutation in *GABRG2*. Clinical features of family A were described previously.¹⁹ This large 5-generation French family included 9 individuals with seizures (table). All 9 patients presented simple FS in early childhood (age at onset range: 12 months to 3 years), 7 of 9 individuals subsequently developed focal epilepsy with EEG and clinical features strongly suggestive of TLE, and 1 patient had only generalized tonic-clonic seizures (GTCS). Brain MRI showed normal hippocampal architecture and volume on both sides in 5 patients. Interictal EEGs showed epileptiform abnormalities localized in the temporal lobe in 6 patients, and was normal in 1 patient (A/II-6) with FS only.

We performed whole-exome sequencing on 3 affected family members (A/II-1, A/II-4, and A/II-9). Originally, a 20 cM spaced genome-wide microsatellite analysis was suggestive of a locus on chromosome 18qter and a probable second locus on chromosome 1q25–q31 with maximum pairwise LOD scores of 3.04 and 2.33, respectively.¹⁹ We first focused the analysis on these 2 regions, then on the rest of the exome dataset. According to our filtering criteria, only 7 variants were common to all 3 siblings, but none of the corresponding genes (*ABL2*, *BOD1L1*, *B3GALT4*, *EXO1*, *HERC4*, *OR5K1*, or *SSH2*) were functionally candidate for epilepsy or expressed in the brain. We therefore subsequently restricted the analysis to the exome datasets of individuals A/II-1 and A/II-4, who belong to the same branch of the family. We identified a heterozygous

Table Clinical features of patients

Subject (age at time of study, y)	GABRG2 mutation	Febrile seizures			Afebrile seizures			MRI	Interictal EEG	Treatment, period, age
		FS	Age at onset, mo	Age at remission, y	Seizure types	Age at onset, y	Age at remission, y			
A/I-1 (87)	p.Glu402fs*3	Yes	14	NA	Focal sz (backward deviation of head, loss of consciousness)	6	7	NA	NA	NA
A/II-1 (66)	p.Glu402fs*3	Yes	24	NA	Focal sz (partial loss of consciousness, disorientation)	4	25	Normal	Left temporal sharp waves	Barbiturates, stopped at 21 y
A/II-3 (67)	p.Glu402fs*3	Yes	18	NA	Focal sz (staring glance, loss of consciousness)	13	20	NA	Left or right temporal sharp waves	Barbiturates, stopped at 20 y
A/II-4 (64)	p.Glu402fs*3	Yes	18	6	GTCS	5	10	NA	NA	Barbiturates
A/II-6 (61)	p.Glu402fs*3	Yes	18	5	No			NA	Normal	None
A/II-9 (49)	None	Yes	12	4	GTCS, focal sz (loss of consciousness, gestural automatisms)	11	14	Normal	Focal slow waves, sparse left frontotemporal sharp waves	Barbiturates, PHT, stopped at 14 y
A/III-1 (33)	p.Glu402fs*3	Yes	12	2.5	Focal sz (thoracic oppression, oroalimentary automatisms)	4	30	Normal	Left temporal sharp waves	VPA, stopped at 24 y (a single sz at 30 y)
A/III-3 (39)	p.Glu402fs*3	Yes	13	5	Focal sz (retrosternal warmth, dreaming state, verbal automatisms)	8	Ongoing	Normal	Left frontotemporal spike waves	Barbiturates, VPA, CBZ, PHT, LTG, VGB
A/III-7 (35)	p.Glu402fs*3	Yes	36	3	Focal sz (loss of consciousness, ambulatory automatisms)	13	32	Normal	Left >right temporal sharp waves	Barbiturates ineffective, switch to VPA
B/II-2 (94)	p.Arg136*	Yes	~24	~4	No			NA	NA	
B/III-2 (55)	NA	Yes	18	4	No			Normal	NA	
B/III-10 (67)	p.Arg136*	Yes	20	4	No			Normal	NA	
B/IV-1 (10)	NA	Yes	22	5	No			Normal	NA	
B/IV-2 (42)	p.Arg136*	Yes	15	4.5	No			Normal	Normal	VPA, 2-5 y
B/IV-4 (31)	p.Arg136*	Yes	13	5	No			Normal	Normal	VPA, 1.5-6 y
B/IV-5 (26)	None	No			GTCS	5	5	Normal (CT scan)	NA	None
B/IV-7 (24)	None	No			Focal sz	8	12	Normal	Centro-temporal spikes with sleep activation	CBZ, 8-15 y
B/IV-9 (28)	None	No			Focal sz	7	10	NA	Centro-temporal spikes with sleep activation	CBZ, 7-16 y
B/V-1 (5)	Unknown	Yes	18	Ongoing	No			NA	NA	
C/II-1 (81)	None	Yes	12	3	No			NA	NA	None
C/III-1 (52)	p.Val462fs*33	Yes	14	<2	No			NA	NA	None
C/IV-1 (22)	p.Val462fs*33	Yes	10	8	No			NA	NA	VPA, 1-3 y
C/IV-2 (21)	p.Val462fs*33	Yes	13	1	No			NA	NA	None
D/II-2 (47)	p.Pro59fs*12	No			TCS	17	~35	NA	NA	CBZ, stopped at ~35 y
D/II-5 (52)	NA	No			TCS, sz with confusion and irresponsiveness	17	Ongoing	NA	NA	PB, CBZ, LCM added recently
D/III-1 (23)	p.Pro59fs*12	Yes	~5	NA	TCS, sz with irresponsiveness	?	Ongoing	NA	NA	CBZ, switch to LCM recently
D/III-5 (26)	NA	Yes	NA	NA	No			NA	NA	None

Continued

Table Continued

Subject (age at time of study, y)	GABRG2 mutation	Febrile seizures			Afebrile seizures					
		FS	Age at onset, mo	Age at remission, y	Seizure types	Age at onset, y	Age at remission, y	MRI	Interictal EEG	Treatment, period, age
D/III-7 (35)	p.Pro59fs*12	Yes	36	~3.5	TCS, sz with irresponsiveness, confusion, or disorientation	2.5	24	NA	NA	VPA, switch to CBZ. Now sz-free with LTG
E/II-1 (56)	p.Met199Val	Yes	6	Childhood	Absences, GTCS	Childhood	25	NA	NA	PB, then VPA. Last seizure at age 25 y
E/III-1 (19)	p.Met199Val	Yes	36	3	Absences, GTCS	3.5	11	NA	NA	VPA, stopped at 14 y
E/III-2 (14)	p.Met199Val	Yes	18	2.5	Absences, GTCS	3-4	12	NA	NA	VPA + ESM, relapse when stopped. Sz-free after restart VPA
F/I-1 (42)	Deletion	Yes	NA	2	No		NA	Normal	NA	None
F/II-1 (8)	Deletion	Yes	12	3	Absences, GTCS	5	NA	Generalized 3-Hz spike waves	Generalized 3-Hz spike waves	VPA

Abbreviations: AED = antiepileptic drug; CBZ = carbamazepine; ESM = ethosuximide; GTCS = generalized tonic-clonic seizures; LCM = lacosamide; LTG = lamotrigine; NA = not available; PB = phenobarbital; PHT = phenytoin; sz = seizure; TCS = tonic-clonic seizures; VGB = vigabatrin; VPA = valproate.

deletion/insertion mutation (c.1206delinsTTCAT) in exon 9 of the $\gamma 2$ subunit of the GABA_A receptor gene *GABRG2* gene (located on chromosome 5) in both A/II-1 and A/II-4. Sanger sequencing indicated that the p.Glu402fs*3 variant was segregated within all affected family members of the first branch, but was not present in individual A/II-9 (figure 1). The variant created a frameshift at codon Glu402 leading to a new reading frame that ended in a stop codon 2 positions downstream (p.Glu402fs*3). Several arguments pointed toward the pathogenicity of the *GABRG2* variant in the family: (1) the *GABRG2* gene is known to be implicated in familial epilepsies; (2) this variant disrupts the reading frame leading to a loss-of-function mechanism, as previously reported for other mutations¹⁶; and (3) this truncating variant segregated among affected family members (apart from A/II-9). We therefore considered individual A/II-9 as a phenocopy. We reviewed the history of seizures of individual A/II-9, which consisted of few episodes of FS between ages 1 and 4 years. During adolescence, she presented a unique probable focal seizure with loss of consciousness and gestural automatisms and 2 GTCS (1 nocturnal and 1 diurnal), over a period of 6 months (period of emotional stress). We also noted that the mother of individual A/II-9 was asymptomatic, as well as her sister and her children, which confirms that this branch of the family was unlikely to bear the same genetic defect.

Mutational screening of *GABRG2* in the follow-up cohort. Sequencing of *GABRG2* was performed in a follow-up cohort of 64 probands from French families and 43 from Italian families with FS with

or without epilepsy (table and figure 1). CGH array was performed in the 43 probands of the Italian families.

Family B was a large multigenerational family, comprising 10 affected individuals, among which 7 patients had simple FS occurring between age 13 and 24 months. All patients had normal development. Two half brothers (B/IV-7 and B/IV-9) presented focal seizures in childhood with no history of FS. EEG and clinical features suggested benign rolandic epilepsy. Patient B/IV-5 presented at age 6 years a single brief afebrile GTCS 2 days after a fall while cycling with loss of consciousness of 10–15 minutes, suggesting a possible posttraumatic event. After the fall, her brain CT scan was normal and EEG 1 month after the accident was normal; she received no treatment. Gene panel sequencing identified a heterozygous nonsense mutation (c.406C>T, p.Arg136*, exon 4) in *GABRG2* in the index case (B/III-10). Subsequent Sanger sequencing revealed that the p.Arg136* mutation segregated with the FS component and was absent in the 2 individuals with focal seizures without FS (B/IV-7 and B/IV-9) and in individual B/IV-5 with a single GTCS and no FS.

Family C consisted of 5 affected individuals over 4 generations. Four patients (C/II-1, C/III-1, C/IV-1, and C/IV-2) had simple FS with an age at onset between 10 and 14 months. No information was available on the epilepsy type of the deceased patient (C/I-1) of the first generation. FS spontaneously remitted before age 3 years, except in individual C/IV-1, whose FS lasted up to age 8 years, therefore designated as FS+. None of the patients had subsequent epilepsy. Sequencing of the index case (C/III-1) revealed

Figure 1 Pedigrees of the families with *GABRG2* mutation segregation

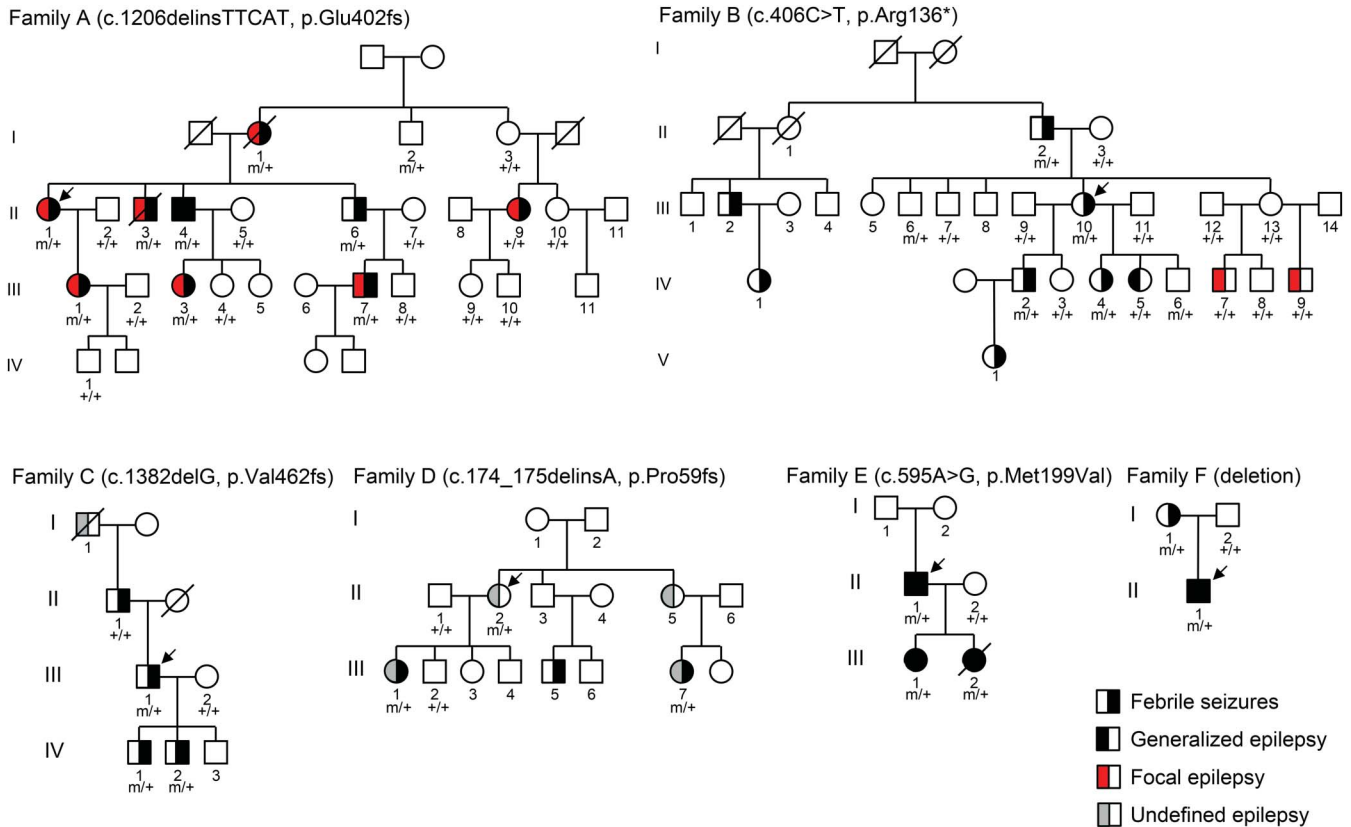

Pedigrees of family A (p.Glu402fs*3), family B (p.Arg136*), family C (p.Val462fs*33), family D (p.Pro59fs*12), family E (p.Met199Val), and family F (*GABRG2* deletion) are represented. The respective *GABRG2* mutations (NM_000816.3) are indicated. Individuals who carry a heterozygous *GABRG2* mutation are denoted by m/+, and those negative for mutations are denoted by +/+. Arrows indicate index cases.

a heterozygous single base deletion (c.1382delG) in exon 9 of *GABRG2*, also present in his affected sons, but not in his father (C/II-1), which is another example of phenocopy. DNA of his mother was not available for genetic studies to investigate the mode of transmission of the mutation. This variant creates a frameshift, resulting in loss of the last 6 C-terminal amino acids and incorporation of 32 extra amino acids with a final predicted peptide of 493 amino acids instead of 467 (p.Val462fs*33).

Family D comprised 5 patients with FS or epilepsy. Medical reports were not available for review, but telephonic interviews with family members revealed that 3 of them (D/III-1, D/III-5, and D/III-7) had a history of FS, 2 of whom developed subsequent tonic-clonic seizures (TCS) and episodes of loss of consciousness (D/III-1 and D/III-7); 2 other family members had TCS (D/II-2) or TCS and episodes of loss of consciousness, both without a known history of FS (D/II-5). Insufficient information was available to classify the epilepsy in the family as generalized or focal. A c.174_175delinsA (p.Pro59fs*12) mutation in exon 2 of *GABRG2* leading to a frameshift starting at codon Pro59 followed by a premature

stop codon after 12 amino acids segregated in the 3 patients whose DNA was available.

Family E comprised a father and 2 daughters with FS, followed by early-onset absence seizures and GTCS. Development was normal in all 3 family members. Despite a high seizure frequency, especially in the father, all became seizure-free with valproate. A missense variant, c.595A>G/p.Met199Val in exon 5 of *GABRG2*, was found in the 3 patients. The variant was predicted deleterious by Sift, disease-causing by MutationTaster, and probably damaging by PolyPhen-2. The p.Met199Val mutation is located in the N-terminal extracellular loop of the protein (figure 2).

An intragenic deletion in the proband of Italian family F and his affected mother was identified at 5q34 spanning 145K at chr5, 160.631.665–161.067.144, and affecting coding exons 1–4 of *GABRG2*. The proband (F/II-1) was an 8-year-old boy who had recurrent episodes of simple FS between ages 12 and 36 months, which remitted spontaneously. From age 5 years, he developed absence seizures and 2 GTCS, successfully treated with valproate. His mother (F/I-1) had 4 episodes of simple FS

Figure 2 Schematic representation of the $\gamma 2$ subunit of the GABA_A receptor with the position of all reported point mutations

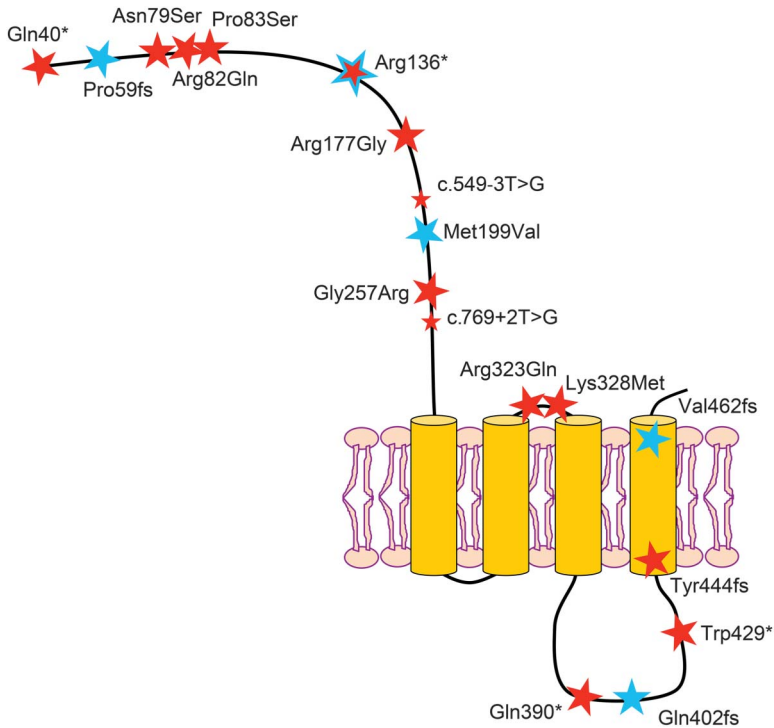

Disease-causing point mutations in *GABRG2* include 8 missense mutations,^{7,22,24,26,27,30,31} 4 nonsense mutations,^{20,23,29,41} 4 frameshifts,²⁵ and 2 splice-sites.^{28,31} Mutations indicated by a blue star were identified in this study; those indicated by a red star were previously reported. All mutations are reported on the immature peptide. Protein structure was designed according to UniProt database information (NP_000807.2).

during her first 2 years of life. Both individuals had normal cognition. No additional affected relatives were reported.

Gene panel sequencing performed in the probands of family B, C, D, and E did not identify other rare variants in known epilepsy genes targeted in our panel. None of the *GABRG2* mutations of this study were reported in the Exome Aggregation Consortium (ExAC) database, which includes the 1000 Genomes project database and the 6,503 exomes listed in the exome variant server. Although we acknowledge that the *p* value might be overestimated because of a lower coverage of exons 3 and 6 in ExAC control individuals, we observed a significant enrichment of rare nonsynonymous *GABRG2* variants in our cohort of patients (6/108, 5.6%) compared with individuals of European ancestry from the ExAC browser (73/33,370 (0.22%), $p < 2.2 \times 10^{-7}$). To further demonstrate the causality of the *GABRG2* variants in the FS phenotype by linkage analysis, we calculated 2-point LOD scores in the 6 families. The sum of the maximal pairwise LOD scores was 3.02, indicating significant likelihood that the *GABRG2* variants are causal.

Four variants (p.Glu402fs*3, p.Arg136*, p.Val462fs*33, and p.Pro59fs*12) were securely

considered pathogenic because they introduced an erroneous stop codon in the reading frame. While p.Arg136* and p.Pro59fs*12 were predicted to be degraded by the nonsense-mediated-decay system (NMD), p.Glu402fs*3 and p.Val462fs*33, located in the last exon of *GABRG2*, may escape the NMD and lead to a truncated or a longer $\gamma 2$ subunit, respectively. The p.Met199Val missense variant was likely to be pathogenic according to 3 in silico prediction tools. All mutations were novel except p.Arg136*, which was previously reported in a family with GEFS+, learning difficulties, and autism spectrum disorder, although it was segregated mostly with the FS component.²⁰

DISCUSSION GABA_A receptors mediate fast inhibitory synaptic transmission in the CNS. GABA_A receptors are heteropentameric ligand-gated chloride channels combining 5 of 19 different subunits. The most common configuration in mammals requires 1 $\gamma 2$ subunit in association with 2 $\alpha 1$ -3 and 2 $\beta 2/3$ subunits.²¹

Up to now, mutations in the *GABRG2* gene, encoding the GABA_A receptor $\gamma 2$ subunit, have been reported in a subset of families, but their prevalence remained unknown. In the literature, individuals with *GABRG2* mutations presented a variety of phenotypes ranging from pure FS,²² FS+ or FS and generalized epilepsy (absence seizures or GTCS),^{7,20,23–29} GTCS without FS,³⁰ FS and rolandic epilepsy,³¹ to possibly Dravet syndrome (a nonsense mutation was reported in dizygotic twins with Dravet syndrome and their healthy father).³²

In this study, we assessed the frequency of *GABRG2* mutations in a large cohort of families with FS and reported pathogenic mutations in 6/108 (5.6%) families. First, we identified a *GABRG2* disease-causing mutation (p.Glu402fs*3) in a multiplex family with FS and TLE, in which linkage analysis previously suggested a possible digenic inheritance on 1q25-q31 and 18qter.¹⁹ However, with the finding of a clear pathogenic mutation in *GABRG2*, leading to the introduction of a premature stop codon (p.Glu402fs*3), both loci were unlikely to cause the phenotype. This study provides a clear example of the limitation of linkage analysis and how phenocopies can distort linkage results (1 affected member of the large family did not carry the *GABRG2* mutation). Unbiased next-generation sequencing approaches will undoubtedly unveil additional erroneous genetic claims in the literature. In the follow-up cohort consisting of 107 families with FS (with or without subsequent epilepsy), we identified 2 other frameshift mutations (p.Val462fs*33 and p.Pro59fs*12), 1 nonsense mutation (p.Arg136*), 1 missense mutation (p.Met199Val), and 1 deletion (exons 1–4) in the *GABRG2* gene. Most patients

carrying a *GABRG2* mutation had a reported history of FS (22/23), associated with TLE in 1 family (family A), generalized epilepsy with absences and GTCS in 2 families (families E and F), and undefined epilepsy with TCS and episodes of loss of consciousness in 1 family (family D). *GABRG2* mutations segregated predominantly with FS, indicating that *GABRG2* mutations are drivers of the FS phenotype, rather than epilepsy. As expected with common traits, several affected family members did not carry a *GABRG2* mutation: 3 family members without a history of FS (B/IV-5, B/IV-7, and B/IV-9) and 2 phenocopies (individuals A/II-9 and C/II-1). Overall, the penetrance of *GABRG2* mutations was high in our cohort, with only one asymptomatic carrier (individual A/I-2). It should be noted though that a history of FS may have been underreported in this generation. The relatively high frequency (5.6%) of *GABRG2* mutations compared with previously published data^{24,28,30} is most probably linked to the fact that FS segregating as an autosomal dominant trait was a study inclusion criterion. Additional genetic or epigenetic modifiers probably determine the associated epilepsy component, which can result either in no subsequent epilepsy or in the development of both generalized and focal seizures. Consistent with this hypothesis, 2 *Gabrg2* knock-in (p.Arg82Gln) mouse models established in 2 different mouse strains exhibited similar temperature-seizure susceptibilities, mimicking the FS phenotype, whereas the epilepsy phenotype was only present in 1 strain.³³ This suggested that FS are less sensitive to genetic background than the associated epileptic phenotypes. An emerging question is how to explain the link between FS and GABAergic defects. Reports have shown that the GEFS+-causing mutation p.Lys328Met affects the membrane dynamics and postsynaptic aggregation of the GABA_A mutant receptor in conditions of increased temperature, confirming the susceptibility to temperature.^{6,34,35}

Currently, a total of 19 different *GABRG2* disease-causing mutations have been reported (including this study), consisting of 8 missense, 4 nonsense, 4 frameshifts, 2 splice-sites, and 1 deletion (figure 2). The high rate of truncating mutations (11/19, 57%), strengthened by this study, strongly suggests that haploinsufficiency resulting in loss of function of GABA_A receptor $\gamma 2$ subunit underlies *GABRG2*-related seizure phenotypes. This is concordant with numerous in vitro functional assays showing that *GABRG2* mutations resulted in mRNA degradation by NMD, the translation of proteins retained in the endoplasmic reticulum with impaired surface-expression, or dysfunctional channel properties of GABA_A receptors^{20,25,31,32,36–38} (for review, see references 15 and 16). However, 2 recent in vivo studies using Gln390*-*Gabrg2* knock-in mice showed that

dominant-negative effects on wild-type $\gamma 2$ and partner subunits also certainly participated to reduce GABA-evoked currents.^{33,39} A reduction in cortical synaptic GABAergic inhibition was confirmed to cause seizures in another p.Arg82Gln-*Gabrg2* knock-in mouse model.⁴⁰ Nevertheless, the link between dysfunctional GABA_A receptors and seizures is still poorly understood.

Mutations in *GABRG2* are more frequent than initially reported, and screening of the gene should be included when considering genetic testing in families with an overall mild phenotype consisting of FS with or without epilepsy.

AUTHOR CONTRIBUTIONS

M. Boillot: drafting the manuscript, analysis and interpretation of genetic data. M. Morin-Brureau: acquisition, analysis, and interpretation of exome data. F. Picard: acquisition and interpretation of clinical data. S. Weckhuysen: interpretation of clinical and genetic data, drafting the manuscript. V. Lambrecq: acquisition and interpretation of clinical data. C. Minetti: acquisition of clinical data. P. Striano: acquisition and interpretation of clinical and genetic data. F. Zara: acquisition and interpretation of clinical and genetic data. M. Iacomino: acquisition and interpretation of genetic data. S. Ishida: acquisition of genetic data. I. An-Gourfinkel: acquisition and interpretation of clinical data. M. Daniau: acquisition of genetic data. K. Hardies: LOD score calculation, M. Baulac: supervising the acquisition and interpretation of clinical data. O. Dulac: supervising the acquisition and interpretation of clinical data. E. Leguern: study design. R. Nabbut: acquisition and interpretation of clinical data and study design. S. Baulac: analysis and interpretation of genetic data, study supervision, drafting the manuscript and obtaining funding. All authors critically reviewed and approved the final manuscript.

ACKNOWLEDGMENT

The authors thank the patients and families for their participation in the study and the sequencing platform of ICM (Y. Marie), the bioinformatics/biostatistics core facility of ICM (J. Guegan), the DNA and cell bank of ICM (C. Dussert and S. Forlani) and Genethon (J. Debusne) for providing technical assistance, and J. Lemke for discussion.

STUDY FUNDING

Supported by the French program “Investissements d’avenir” (ANR-10-IAIHU-06), the Fondation Française pour la Recherche sur l’Epilepsie (FFRE), and the Association de Recherche sur la Génétique des Epilepsies (ARGE).

DISCLOSURE

M. Boillot has received research support from the Ligue Française contre l’Epilepsie (LFCE). M. Morin-Brureau reports no disclosures. F. Picard has received a grant from the Swiss National Foundation (No. 320030-127608). S. Weckhuysen has received research support from the French program “Investissements d’avenir” (ANR-10-IAIHU-06). V. Lambrecq has received research support from the French program “Investissements d’avenir” (ANR-10-IAIHU-06). C. Minetti reports no disclosures. P. Striano has received research support from the Italian ministry of health (project GR-2009-1473821). F. Zara and M. Iacomino report no disclosures. S. Ishida has received research support from the Japan Society for the Promotion of Science (JSPS). I. An-Gourfinkel and M. Daniau report no disclosures. K. Hardies has been a PhD fellow of the Institute for Science and Technology (IWT)-Flanders. M. Baulac has served on the scientific advisory boards of UCB, Eisai, GSK, SAGE, GW Pharmaceuticals; has received travel support and/or honoraria from UCB and Eisai GSK; and has been a consultant for UCB, Eisai, and GSK. O. Dulac reports no disclosures. E. Leguern has received research support from Program “Investissements d’avenir” ANR-10-IAIHU-0, INSERM, and Assistance Publique des Hôpitaux de Paris. R. Nabbut has served

on the scientific advisory board for Novartis; has received travel support from Shire and speaker honoraria from Novartis, Cyberonics, and Eisai; and has served on the editorial board for *Epilepsia*. S. Baulac has received research support from Program "Investissements d'avenir" ANR-10-IAIHU-06 and Carnot Institute (No. CT010). Go to Neurology.org/ng for full disclosure forms.

Received June 25, 2015. Accepted in final form September 30, 2015.

REFERENCES

1. Nelson KB, Ellenberg JH. Predictors of epilepsy in children who have experienced febrile seizures. *N Engl J Med* 1976;295:1029–1033.
2. Johnson WG, Kugler SL, Stenroos ES, et al. Pedigree analysis in families with febrile seizures. *Am J Med Genet* 1996;61:345–352.
3. Saghazadeh A, Mastrangelo M, Rezaei N. Genetic background of febrile seizures. *Rev Neurosci* 2014;25:129–161.
4. Scheffer IE, Zhang YH, Jansen FE, Dibbens L. Dravet syndrome or genetic (generalized) epilepsy with febrile seizures plus? *Brain Dev* 2009;31:394–400.
5. Wallace RH, Wang DW, Singh R, et al. Febrile seizures and generalized epilepsy associated with a mutation in the Na⁺-channel beta1 subunit gene SCN1B. *Nat Genet* 1998;19:366–370.
6. Escayg A, MacDonald BT, Meisler MH, Baulac S, Huberfeld G, An-Gourfinkel I. Mutations of SCN1A, encoding a neuronal sodium channel, in two families with GEFS+2. *Nat Genet* 2000;24:343–345.
7. Baulac S, Huberfeld G, Gourfinkel-An I, Mitropoulou G, Beranger A, Prud'homme JF. First genetic evidence of GABA(A) receptor dysfunction in epilepsy: a mutation in the gamma2-subunit gene. *Nat Genet* 2001;28:46–48.
8. Baulac S, Gourfinkel-An I, Nabbout R, Huberfeld G, Serratosa J, Leguern E. Fever, genes, and epilepsy. *Lancet Neurol* 2004;3:421–430.
9. Audenaert D, Van Broeckhoven C, De Jonghe P. Genes and loci involved in febrile seizures and related epilepsy syndromes. *Hum Mutat* 2006;27:391–401.
10. Escayg A, Goldin AL. Sodium channel SCN1A and epilepsy: mutations and mechanisms. *Epilepsia* 2010;51:1650–1658.
11. Schubert J, Siekierska A, Langlois M, May P, Huneau C, Becker F. Mutations in STX1B, encoding a presynaptic protein, cause fever-associated epilepsy syndromes. *Nat Genet* 2014;46:1327–1332.
12. Ishida S, Picard F, Rudolf G, Noé E, Achaz G, Thomas P. Mutations of DEPDC5 cause autosomal dominant focal epilepsies. *Nat Genet* 2013;45:552–555.
13. Madia F, Gennaro E, Cecconi M, Buti D, Capovilla G, Dalla Bernardina B. No evidence of GABRG2 mutations in severe myoclonic epilepsy of infancy. *Epilepsy Res* 2003;53:196–200.
14. MacArthur DG, Manolio TA, Dimmock DP, Rehm HL, Shendure J, Abecasis GR. Guidelines for investigating causality of sequence variants in human disease. *Nature* 2014;508:469–476.
15. Macdonald RL, Kang JQ, Gallagher MJ. GABAA receptor subunit mutations and genetic epilepsies. In: Noebels JL, Avoli M, Rogawski MA, et al, eds. *Jasper's Basic Mechanisms of the Epilepsies*, 4th ed. Bethesda: National Center for Biotechnology Information; 2012.
16. Hirose S. Mutant GABA(A) receptor subunits in genetic (idiopathic) epilepsy. *Prog Brain Res* 2014;213:55–85.
17. Baulac S, Gourfinkel-An I, Picard F, Rosenberg-Bourgin M, Prud'homme JF, Baulac M. A second locus for familial generalized epilepsy with febrile seizures plus maps to chromosome 2q21–q33. *Am J Hum Genet* 1999;65:1078–1085.
18. Striano P, Coppola A, Paravidino R, Malacarne M, Gimelli S, Robbiano A. Clinical significance of rare copy number variations in epilepsy: a case-control survey using microarray-based comparative genomic hybridization. *Arch Neurol* 2012;69:322–330.
19. Baulac S, Picard F, Herman A, Feingold J, Genin E, Hirsch E. Evidence for digenic inheritance in a family with both febrile convulsions and temporal lobe epilepsy implicating chromosomes 18qter and 1q25–q31. *Ann Neurol* 2001;49:786–792.
20. Johnston AJ, Kang JQ, Shen W, Pickrell WO, Cushion TD, Davies JS. A novel GABRG2 mutation, p.R136*, in a family with GEFS+ and extended phenotypes. *Neurobiol Dis* 2014;64:131–141.
21. Farrant M, Nusser Z. Variations on an inhibitory theme: phasic and tonic activation of GABA(A) receptors. *Nat Rev Neurosci* 2005;6:215–229.
22. Audenaert D, Schwartz E, Claeys KG, Claes L, Deprez L, Suls A. A novel GABRG2 mutation associated with febrile seizures. *Neurology* 2006;67:687–690.
23. Sun H, Zhang Y, Liang J, Liu X, Ma X, Wu H. SCN1A, SCN1B, and GABRG2 gene mutation analysis in Chinese families with generalized epilepsy with febrile seizures plus. *J Hum Genet* 2008;53:769–774.
24. Lachance-Touchette P, Brown P, Meloche C, Kinirons P, Lapointe L, Lacasse H. Novel alpha1 and gamma2 GABAA receptor subunit mutations in families with idiopathic generalized epilepsy. *Eur J Neurosci* 2011;34:237–249.
25. Tian M, Mei D, Freri E, Hernandez CC, Granata T, Shen W. Impaired surface alphabeta gamma GABA(A) receptor expression in familial epilepsy due to a GABRG2 frameshift mutation. *Neurobiol Dis* 2013;50:135–141.
26. Carvill GL, Heavin SB, Yendle SC, McMahon JM, O'Roak BJ, Cook J. Targeted resequencing in epileptic encephalopathies identifies de novo mutations in CHD2 and SYNGAP1. *Nat Genet* 2013;45:825–830.
27. Wallace RH, Marini C, Petrou S, Harkin LA, Bowser DN, Panchal RG. Mutant GABA(A) receptor gamma2-subunit in childhood absence epilepsy and febrile seizures. *Nat Genet* 2001;28:49–52.
28. Kananura C, Haug K, Sander T, Runge U, Gu W, Hallmann K. A splice-site mutation in GABRG2 associated with childhood absence epilepsy and febrile convulsions. *Arch Neurol* 2002;59:1137–1141.
29. Harkin LA, Bowser DN, Dibbens LM, Singh R, Phillips F, Wallace RH. Truncation of the GABA(A)-receptor gamma2 subunit in a family with generalized epilepsy with febrile seizures plus. *Am J Hum Genet* 2002;70:530–536.
30. Shi X, Huang MC, Ishii A, Yoshida S, Okada M, Morita K. Mutational analysis of GABRG2 in a Japanese cohort with childhood epilepsies. *J Hum Genet* 2010;55:375–378.
31. Reinthaler EM, Dejanovic B, Lal D, Semtner M, Merkler Y, Reinhold A. Rare variants in gamma-aminobutyric acid type A receptor genes in rolandic epilepsy and related syndromes. *Ann Neurol* 2015;77:972–986.

32. Ishii A, Kanaumi T, Sohda M, Misumi Y, Zhang B, Kakinuma N. Association of nonsense mutation in GABRG2 with abnormal trafficking of GABAA receptors in severe epilepsy. *Epilepsy Res* 2014;108:420–432.
33. Reid CA, Kim T, Phillips AM, Low J, Berkovic SF, Luscher B. Multiple molecular mechanisms for a single GABAA mutation in epilepsy. *Neurology* 2013;80:1003–1008.
34. Eugene E, Depienne C, Baulac S, Baulac M, Fritschy JM, Le Guern E. GABA(A) receptor gamma 2 subunit mutations linked to human epileptic syndromes differentially affect phasic and tonic inhibition. *J Neurosci* 2007;27:14108–14116.
35. Bouthour W, Leroy F, Emmanuelli C, Carnaud M, Dahan M, Ponce JC. A human mutation in Gabrg2 associated with generalized epilepsy alters the membrane dynamics of GABAA receptors. *Cereb Cortex* 2012;22:1542–1553.
36. Huang X, Tian M, Hernandez CC. The GABRG2 nonsense mutation, Q40X, associated with Dravet syndrome activated NMD and generated a truncated subunit that was partially rescued by aminoglycoside-induced stop codon read-through. *Neurobiol Dis* 2012;48:115–123.
37. Kang JQ, Shen W, Macdonald RL. The GABRG2 mutation, Q351X, associated with generalized epilepsy with febrile seizures plus, has both loss of function and dominant-negative suppression. *J Neurosci* 2009;29:2845–2856.
38. Kang JQ, Shen W, Macdonald RL. Trafficking-deficient mutant GABRG2 subunit amount may modify epilepsy phenotype. *Ann Neurol* 2013;74:547–559.
39. Kang JQ, Shen W, Zhou C, Xu D, Macdonald RL. The human epilepsy mutation GABRG2(Q390X) causes chronic subunit accumulation and neurodegeneration. *Nat Neuroscience* 2015;18:988–996.
40. Tan HO, Reid CA, Single FN, Davies PJ, Chiu C, Murphy S. Reduced cortical inhibition in a mouse model of familial childhood absence epilepsy. *Proc Natl Acad Sci U S A* 2007;104:17536–17541.
41. Hirose S. A new paradigm of channelopathy in epilepsy syndromes: intracellular trafficking abnormality of channel molecules. *Epilepsy Res* 2006;70(suppl 1):S206–S217.

Neurology[®] Genetics

Novel *GABRG2* mutations cause familial febrile seizures
Morgane Boillot, Mélanie Morin-Brureau, Fabienne Picard, et al.
Neurol Genet 2015;1;
DOI 10.1212/NXG.0000000000000035

This information is current as of November 4, 2015

Updated Information & Services	including high resolution figures, can be found at: http://ng.neurology.org/content/1/4/e35.full.html
References	This article cites 40 articles, 3 of which you can access for free at: http://ng.neurology.org/content/1/4/e35.full.html##ref-list-1
Citations	This article has been cited by 3 HighWire-hosted articles: http://ng.neurology.org/content/1/4/e35.full.html##otherarticles
Subspecialty Collections	This article, along with others on similar topics, appears in the following collection(s): All Epilepsy/Seizures http://ng.neurology.org/cgi/collection/all_epilepsy_seizures Genetic linkage http://ng.neurology.org/cgi/collection/genetic_linkage
Permissions & Licensing	Information about reproducing this article in parts (figures, tables) or in its entirety can be found online at: http://ng.neurology.org/misc/about.xhtml#permissions
Reprints	Information about ordering reprints can be found online: http://ng.neurology.org/misc/addir.xhtml#reprintsus

Neurol Genet is an official journal of the American Academy of Neurology. Published since April 2015, it is an open-access, online-only, continuous publication journal. Copyright © 2015 American Academy of Neurology. All rights reserved. Online ISSN: 2376-7839.

